

## Features

### Briggs & Stratton Vanguard engine

Premium-grade Vanguard engines are application-engineered to operate in tough conditions.

### MAUX auxiliary system

Ensures the generator end can withstand 300% motor starting inrush for 20 seconds.

### Low oil protection

In the event there is low-oil pressure, the engine will shut down, which will protect the engine from damage.

### Premium Square D circuit breakers

Providing clear and instant identification of a tripped circuit with a Visi-Trip indicator.

### Vacuum Fuel Pump

2 feet fuel lift capability.

### 100% load tested

You won't find statistical sampling here. We load test every generator before it leaves our facility.

## EMERGEN-C VEHICLE MOUNTED

**22,000 Surge Watts**

**19,000 Continuous Watts**



### 80 AMP CIRCUIT BREAKER

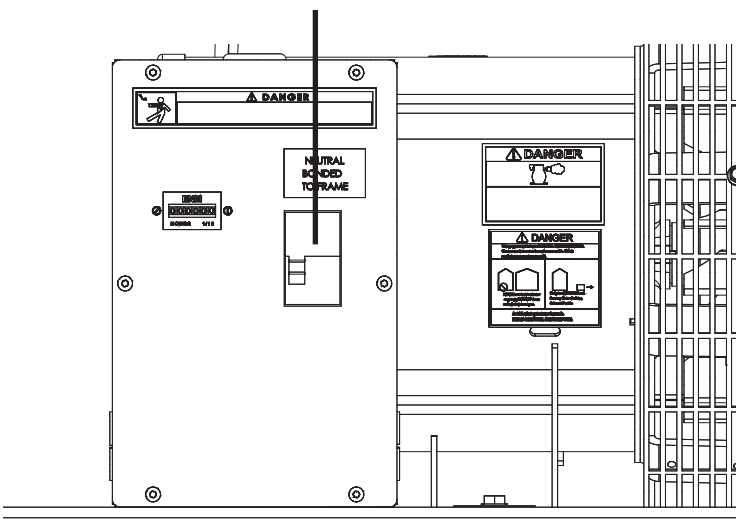

## Optional Accessories

### Fuel System

Includes 15 gallon composite fuel tank, primer bulb, fuel cap with gauge, carbon canister, fuel line, connectors, and brackets.

### Maintenance kit

Keep the engine at its peak performance to ensure the generator will be ready when needed most.

### Battery

Premium Interstate Group 26 500 CCA battery for a quick, reliable start-up.

## GENERATOR

SURGE WATTS	22,000
CONTINUOUS WATTS	19,000
AMPS @ 240V	79
OUTPUT	120/240 VAC
VOLTAGE REGULATION	AVR +/-1.5%
MAIN CIRCUIT BREAKER	80 AMP, 240 VAC
BONDED NEUTRAL	YES
120/240 VOLT RECEPTACLES	N/A
GENERATOR WARRANTY <sup>(1)</sup>	2 YRS

NOTES: (1) For more generator warranty information contact your local WINCO dealer.

## FUEL CONSUMPTION

100% LOAD	3.28 GAL/HR
75% LOAD	2.57 GAL/HR
50% LOAD	1.88 GAL/HR
25% LOAD	1.43 GAL/HR
0% LOAD	0.95 GAL/HR

## SHIPPING

DIMENSIONS (LxWxH)	38" x 21.5" x 25"
NET WEIGHT	305 LBS
SHIPPING DIMENSIONS	50" x 27" x 32"
SHIP WEIGHT	495 LBS
FREIGHT CLASS	70

## ENGINE

ENGINE BRAND	BRIGGS & STRATTON
ENGINE MODEL	VANGUARD
ENGINE STARTER	ELECTRIC
ENGINE SPEED	3600 RPM
ENGINE CYLINDERS	V-TWIN
DISPLACEMENT/TYPE	993 CC / OHV
LOW OIL PROTECTION	STANDARD
RECOMMENDED OIL <sup>(1)</sup>	10W-30
OIL CAPACITY	2.5 QT
dBA AT 7 METERS	79
FUEL SYSTEM	OPTIONAL
HOUR METER	YES
MOTOR STARTING (CODE G) <sup>(2)</sup>	N/A
EPA APPROVED	YES
CARB APPROVED	NO
CSA APPROVED	NO
BATTERY SIZE <sup>(3)</sup>	BCI GROUP 26 500 CCA
ENGINE WARRANTY <sup>(4)</sup>	3 YRS COMMERCIAL

NOTES: (1) The oil recommended is for normal applications. See operator's manual for the recommended oil for your needs. (2) Code G capacitor start motor. (3) Battery not included (4) Contact your local Honda service center for engine warranty assistance.

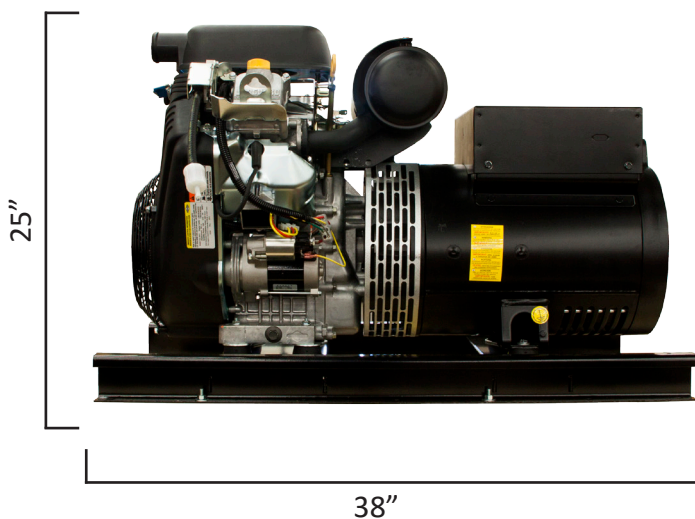

Specifications are subject to change without notice.  
225 S. Cordova Ave Le Center MN • 1-800-733-2112 • www.wincogen.com