

# **WINCO**<sup>®</sup>

## **W3000H/C GENERATOR**

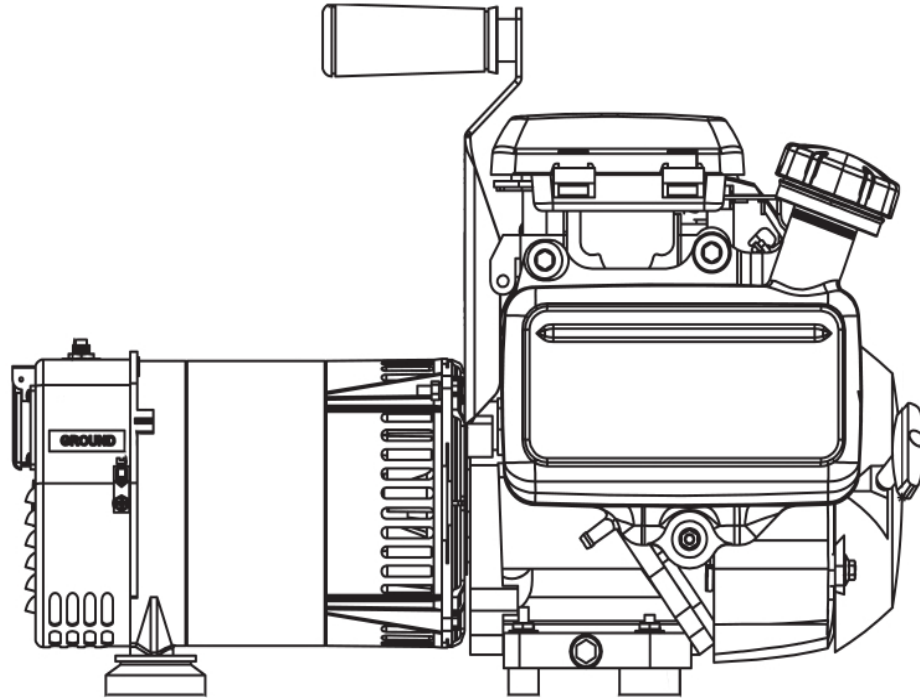

# **INSTALLATION AND OPERATORS MANUAL**

WINCO INC. 225 S. CORDOVA AVE. LE CENTER, MN 56057  
SALES DEPT. 507-357-6821  
SERVICE DEPT. 507-357-6831  
[www.wincogen.com](http://www.wincogen.com)

# TABLE OF CONTENTS

## SAVE THESE INSTRUCTIONS

### SPECIFICATIONS

GENERATOR  
ENGINE

### TESTING POLICY

### SAFETY

IMPORTANT SAFETY INSTRUCTIONS  
CALIFORNIA PROPOSITION 65  
ANSI SAFETY DEFINITIONS

### INTRODUCTION

INTENDED USES  
RESTRICTED USES

### UNIT CAPABILITIES

GENERATOR CONNECTIONS  
STARTING ELECTRIC MOTORS  
LOAD TYPES

### PREPARING THE UNIT

UNPACKING  
LUBRICATION  
GASOLINE

### INITIAL START UP

BASIC OPERATION  
STARTING HINTS  
STOPPING  
OPERATING SPEED

### CONNECTING THE LOADS

APPLYING THE LOADS  
GROUNDING  
WIRING

### ENGINE CARE

MAINTENANCE SCHEDULE  
CHANGING THE OIL

### GENERATOR CARE

EXERCISING THE GENERATOR  
GENERATOR MAINTENANCE  
CLEANING  
AIR FILTER  
SPARK PLUG

### TROUBLESHOOTING

### CONTROL PANEL WIRING DIAGRAM

### 12 MONTH LIMITED WARRANTY

	COPY YOUR MODEL AND SERIAL NUMBER HERE
2	No other WINCO generator has the same serial number as yours. If you should ever need to contact us concerning this unit, it will help us to respond to your needs faster.
3	MODEL _____
	SERIAL NUMBER _____
3	PURCHASE DATE _____
3	DEALER NAME _____
	DEALER PHONE # _____
4	
5	<b>SAVE THESE INSTRUCTIONS</b>
	This manual contains important instructions that should be followed during installation and maintenance of the generator. Read and understand all instructions in the manual before starting and operating the generator.
6	
	USING THIS MANUAL
7	Congratulations on your choice of a WINCO generator. You have selected a high-quality, precision-engineered generator designed and tested to give you years of satisfactory service.
	To get the best performance from your new generator, it is important that you carefully read and follow the operating instructions in this manual.
8	
	Should you experience a problem please follow the "Troubleshooting Tables" near the end of this manual. The warranty listed in the manual describes what you can expect from WINCO should you need service assistance in the future.
9	
10	
11	
11	
12	

# SPECIFICATIONS

## GENERATOR

Model	W3000H
Starting Watts	3,000
Running Watts	2,400
Volts	120
Starting Amps	25
Running Amps	20
Generator Manufacturer	Mecc Alte Spa
Generator Model Number	SF15W-75
Part Number	16346-008
Rotor Resistance	4.356 Ohms
Stator Resistance	2.165 Ohms
Regulation	Capacitor

## ENGINE

Engine Manufacturer	Honda
Engine Model Number	GC160 LVXA
Fuel Type	Gasoline
Oil Capacity	20 oz. (0.625 qts)

# TESTING POLICY

Before any generator is shipped from the factory, it is fully checked for performance. The generator is loaded to its full capacity, and the voltage, current, and frequency are carefully checked.

Rated output of generator is based on engineering tests of typical units, and is subject to, and limited by, the temperature, altitude, fuel, and other conditions specified by the manufacturer of applicable engines.

# SAFETY

## IMPORTANT SAFETY INSTRUCTIONS

### SAVE THESE INSTRUCTIONS

This manual contains important information that should be understood and followed before the installation, operation and maintenance of the generator. Failure to follow the safety instructions in this manual could result in serious injury or death. Keep this manual available for future reference.

## CALIFORNIA PROPOSITION 65



**WARNING:** *This product contains crude oil, gasoline, diesel fuel and other petroleum products, Antifreeze to which can expose you to chemicals including toluene and benzene, Ethylene glycol (ingested) which are known to the State of California to cause cancer, birth defects or other reproductive harm and developmental issues. For more information go to [www.P65Warning.ca.gov](http://www.P65Warning.ca.gov).*

## ANSI SAFETY DEFINITIONS

### DANGER:

*DANGER indicates an imminently hazardous situation which, if not avoided, **will** result in death or serious injury. This signal word is to be limited to the most extreme situations.*

### WARNING:

*WARNING indicates a potentially hazardous situation which, if not avoided, **could** result in death or serious injury.*

### CAUTION:

*CAUTION indicates a potentially hazardous situation which, if not avoided, **may** result in minor or moderate injury. It may be used to alert against unsafe practices.*

*NOTE: CAUTION is also used on the unit labels and in this manual to indicate a situation that could result in serious damage or destruction of the equipment and possible personal injury.*

### 1. ELECTRICAL SHOCK -

The output voltage present in this equipment can cause fatal electric shock. This equipment must be operated by a responsible person.

- A. Do not allow anyone to operate the generator without proper instruction.
- B. Guard against electric shock.
- C. Avoid contact with live terminals or receptacles.
- D. Use extreme care if operating this unit in rain or snow.
- E. Use only three-pronged grounded receptacles and extension cords.
- F. Be sure the unit is properly grounded or your application.

### 2. FIRE HAZARD -

Gasoline and other fuels present a hazard of possible explosion and/or fire.

- A. Do not refuel when the engine is running or hot.
- B. Keep fuel containers out of reach of children.
- C. Do not smoke or use open flame near the generator set or fuel tank.
- D. Keep a fire extinguisher nearby and know its proper use. Fire extinguishers rated ABC by NFPA are appropriate.
- E. Store fuel only in an approved container, and only in a well ventilated area.
- F. Follow local codes for closeness to combustible material.

### 3. DEADLY EXHAUST GAS -

Exhaust fumes from any gasoline engine contain carbon monoxide, an invisible, odorless and deadly gas that must be mixed with fresh air.

- A. Operate only in well ventilated areas.
- B. Never operate indoors including attached garages
- C. Never operate the unit in such a way as to allow exhaust gases to seep back into closed rooms (i.e. through windows, walls, floors).

### 4. NOISE HAZARD -

Excessive noise is not only tiring, but continual exposure can lead to loss of hearing.

- A. Use hearing protection when working around this equipment for long periods of time.
- B. Keep your neighbors in mind when using this equipment.

### 5. CLEANLINESS -

Keep the generator and surrounding area clean.

- A. Remove all grease, ice, snow or materials that create slippery conditions around the unit.
- B. Remove any rags or other materials that could create a potential fire hazard.
- C. Carefully clean up any gas or oil spills before starting the unit.

### 6. SERVICING EQUIPMENT -

All service, including the installation or replacement of service parts, should be performed only by a qualified technician.

- A. Use only factory approved repair parts.
- B. Do not work on this equipment when fatigued.
- C. Never remove the protective guards, covers, or receptacle panels while the engine is running.
- D. Use extreme caution when working on electrical components. High output voltage from this equipment can cause serious injury or death.
- E. Always avoid hot mufflers, exhaust manifolds, and engine parts. They can cause severe burns instantly.
- F. The use of the engine-generator set must comply with all national, state, and local codes.

## INTRODUCTION

### INTENDED USES

This engine generator set has been designed primarily for portable commercial use. 120 volt receptacles are provided in the control panel to plug in your loads (lights, portable tools, and small appliances).

This portable unit requires large quantities of fresh air for cooling the engine and generator. For safety, long life and adequate performance, these units should never be run in small compartments without positive fresh air flow.

### RESTRICTED USES

**DO NOT** operate generator where it could get wet or have pooling water near it. This generator is NOT weatherproof. Failing to keep generator in a dry area may cause an electrical shock, resulting in injury or death.

**DO NOT** operate and/or store the unit outside during inclement weather without adequate protection from the elements. Failure to do so will damage the unit.

**DO NOT** remove from the cradle assembly. Removal of the generator from the cradle assembly may cause excessive vibration and damage to the engine-generator set.

**DO NOT** install and operate this generator in a small compartment, i.e. generator compartments of vehicles, motor homes or travel trailers. These compartments will not allow enough free flow of fresh air to reach the engine generator set for cooling and will cause the unit to overheat, damaging both the engine and generator. Small compartments will also develop hot spots where there is very little air flow and may cause a fire.

**PLEASE NOTE** There are 3rd party companies making enclosures for generators that have been properly engineered. The use of these 3rd party enclosures is acceptable as long as they have been engineered and meet applicable code.

**DO NOT** attempt to operate at 50 cycles. These units are designed and governed to operate at 60 cycles only.

# UNIT CAPABILITIES

## GENERATOR CONNECTIONS

W3000H: 120 volt receptacles are provided for connection to various loads. The following diagram represents this 2,400 watt (rated output) generator. This generator is capable of producing 20 Amps of 120 volt current at A. Check the appliance or tool nameplates for the current and voltage to insure compatibility.

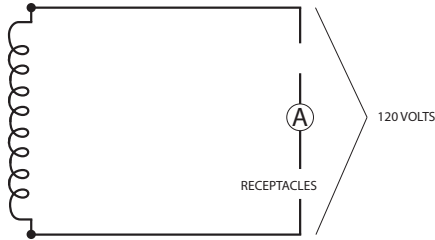

## STARTING ELECTRIC MOTORS

Electric motors require much more current (amps) to start them than to run them. Some motors, particularly low cost split-phase motors, are very hard to start and require 5 to 7 times as much starting current as running current. Capacitor motors are easier to start and usually require 2 to 4 times as much starting current as running current. Repulsion Induction motors are the easiest to start and require only 1 1/2 to 2 1/2 times as much starting as running current.

Most fractional horsepower motors take about the same amount of current to run them whether they are Repulsion Induction (RI), Capacitor (Cap), or Split-Phase (SP) type. The following chart shows the approximate current required to start and run various types and sizes of 120 Volt 60 cycle electric motors under average load conditions.

		STARTING AMPS		
HP	Running Amps	Split Phase Motor	Capacitor Motor	Repulsion Induction Motor
1/6	3.2	16 to 22	6 to 13	5 to 8
1/4	4.5	22 to 32	9 to 18	7 to 12
1/3	5.2	26 to 35	10 to 21	8 to 17
1/2	7.2	Not Made	14 to 29	11 to 18
1	13	Not Made	26 to 52	20 to 33

The figures given in the previous chart are for an average load such as a blower or fan. If the electric motor is connected to a hard starting load such as an air compressor, it will require more starting current. If it is connected to a light load, or no load such as a power saw, it will require less starting current. The exact requirement will also vary with the brand or design of the motor.

Self-exciting generators respond to severe overloading differently than utility power. When overloaded, the engine is not able to supply enough power to bring the electric motor up to operating speed. The generator responds with high initial starting current, but the engine speed drops sharply. The overload may stall the engine. If allowed to operate at very low speeds, the electric motor starting winding will burn out in a short time. The generator winding may also be damaged.

## CAUTION: EQUIPMENT DAMAGE

*Running the generator set under these conditions may result in damage to the generator stator as well as the motor winding.*

The heavy surge of current required for starting motors is required for only an instant. The generator will not be damaged if it can bring the motor up to speed in a few seconds of time. If difficulty is experienced in starting motors, turn all other electrical loads off and if possible reduce the load on the electric motor.

Motor starting capacity - 0.75 HP code 'G' capacitor start engine.

Trying to start a larger motor or higher code motor, i.e. 'J' or 'K', may result in damage to both the generator and the electric motor, especially 120 Volt motors.

## LOAD TYPES

This generator is designed and rated for general commercial use. The running watts rating assumes a variable load. If your application has a fixed load that does not vary, an additional derate of 20% from the running watts is recommended to ensure the longest useful life of the engine and generator end.

# PREPARING THE UNIT

## UNPACKING

### CAUTION: EQUIPMENT DAMAGE

*Always check oil level prior to use. Failure to maintain the engine oil at the proper level will result in serious engine damage.*

When you unpack your engine-generator set be sure to remove all the information sheets and manuals from the carton.

1. As you receive your unit, it is critical to check it for any damage. If any damage is noted, it is always easiest to refuse the shipment and let WINCO take care of the freight claim. If you sign for the unit, the transfer of the ownership requires that you file the freight claim
2. Before proceeding with the preparations of your new generator for operation, take a couple of minutes to ensure the unit you have received is the correct model and review the specification pages in this manual to ensure that this unit meets your job requirements.

## LUBRICATION

### CAUTION: EQUIPMENT DAMAGE

*Failure to maintain the engine oil at the proper level will result in serious engine damage.*

Before starting the engine, verify the crankcase is filled to the proper level with a good quality oil. The recommended grade oil and quantity of oil required is listed in the engine operator's manual and under the service tab in this manual. This unit was shipped with oil in it. The engine normally holds 0.625 quarts (20 oz.) of oil. Use the dipstick to ensure that you have the proper oil level in the crankcase. The full oil level mark on the dipstick is depicted in the following image.

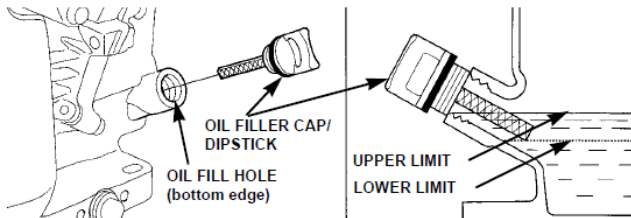

For instructions on changing the oil and oil recommendations, see the ENGINE CARE section in this manual.

**NOTE:** This engine generator must be on a level surface before you check or add oil to the system.

The necessity of using the correct oil and keeping the crankcase full cannot be overemphasized. Engine failures resulting from inadequate or improper lubricant are considered abuse and not covered by the generator or engine manufacturer's warranty.

## GASOLINE

When using gasoline always use a good grade of unleaded fuel. This engine is certified to operate on unleaded gasoline with a pump octane rating of 86 or higher. Gasoline containing no more than 10% ethanol (E10) or 5% methanol by volume may be used. In addition methanol must contain co-solvents and corrosion inhibitors. Use of fuels with content of ethanol or methanol greater than shown above may cause starting and/or performance problems. Always insure that the fuel is clean and free of all impurities.

### WARNING: FIRE DANGER

*Gasoline and its fumes are VERY explosive when proper precautions are not taken.*

Never use fuel that has been stored for an extended period of time. Fuel will lose its volatile properties and you will be left with a 'gum' or varnish residue. This varnish-like substance will clog the filters, fuel lines, and injectors. Old, contaminated, stale fuel will not burn properly. The use of a fuel additive, such as Sta-Bil, or an equivalent will minimize the formation of fuel gum deposits. If a unit has been out of operation for an extended period of time, it is best to drain old fuel from the engine and replace with fresh fuel before attempting to start.

## OIL ALERT SYSTEM

The Oil Alert system is designed to prevent engine damage caused by insufficient amount of oil in the crankcase. Before the oil level in the crankcase can fall below a safe limit, the Oil Alert system will automatically stop the engine.



# INITIAL START UP

The throttle control on these generators is preset and locked to operate at 3600 RPM (nominal) with no load speed set at 3690 RPM. Only a trained service technician should be allowed to adjust this speed setting.

## NOTICE: ENGINE START LOCKOUT

*This unit will not start if it is low on oil. The lubricating oil level must be at the full mark before the engine will start and run. This engine will not start without a battery. The fuel shut-off solenoid requires 12V DC to operate.*

## BASIC OPERATION

1. Check oil level, refill as needed.
2. Pull the choke rod out to the closed position.

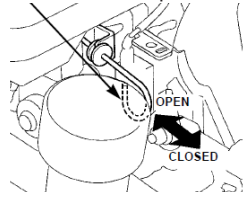

3. Move the ON/OFF lever to the ON position

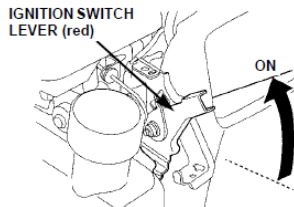

4. Pull the starter grip lightly until resistance is felt, then pull briskly.

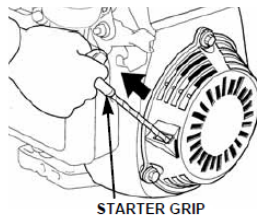

## CAUTION: EQUIPMENT DAMAGE

*Do not allow the starter grip to snap back against the engine. Return it gently to prevent damage to the starter.*

5. If the choke rod was pulled to the closed position to start the engine, push it to the open position as soon as the engine warms up enough to run smoothly.

## CAUTION: EQUIPMENT DAMAGE

*Never permit the choke to remain in the on after the engine has run for a short time. It is not necessary to choke the engine when it is warm.. Avoid over-choking.*

## STARTING HINTS

### 1. COLD WEATHER

- A. Use the proper oil for the temperature expected.
- B. Use fresh winter grade fuel. Winter grade gasoline is blended to improve starting. Do not use summer gasoline.
- C. A slightly richer fuel mixture will usually improve cold starting.

## CAUTION: EQUIPMENT DAMAGE

*Never use ether or any other starting aides. Serious engine damage or personal injury may result from ignoring this simple warning.*

### 2. HOT WEATHER

- A. Use the proper oil for the temperature expected.
- B. Use only summer blended gasoline. Using gasoline left over from winter may cause the unit to vapor lock.

## STOPPING

1. Move the ON/OFF lever to the OFF position.
2. Before extended storage (over 30 days) certain precautions must be taken care of to ensure the fuel doesn't deteriorate and clog the fuel system. Note: The use of a fuel additive, such as STA-BIL or an equivalent will minimize the formation of gum deposits during storage. Such an additive may be added to gasoline in the engines fuel tank or to gasoline in a storage container.
  - A. Remove the remaining fuel from the fuel tank.
  - B. Start the engine and allow it to run until all the fuel in the carburetor and the fuel lines has been used up and the engine stops.
  - C. While the engine is warm, drain the oil and refill with fresh oil.
  - D. Remove the spark plug, pour approximately 1/2 ounce (15 cc) of engine oil into the cylinder and crank slowly to distribute the oil. Replace the spark plug.
  - E. Clean dirt and chaff from cylinder, cylinder head fins, blower housing, screen and muffler areas.
  - F. Store in a clean and dry area.

## OPERATING SPEED

All engines have a tendency to slow down when a load is applied. When the electrical load is connected to the generator, the engine is more heavily loaded, and as a result, the speed drops slightly. This slight decrease in speed, together with the voltage drop within the generator itself, results in a slightly lower voltage when the generator is loaded to its full capacity than when running no load. The slight variation in speed also affects the frequency of the output current. This frequency variation has no appreciable effect in the operation of motors, lights, and most appliances. However, electronic equipment and clocks will be affected if correct RPM is not maintained. See Load vs. Output chart.

Although individual units and models vary slightly, the normal voltage and frequency of the engine-generator described in this manual are approximately as follows, under varying loads:

LOAD vs. OUTPUT			
Generator Load	Speed (RPM)	Frequency (Hz)	Voltage
None	3690	61.5	120V
Half	3600	60.0	120V
Full	3510	58.5	120V

The speed of the engine was carefully adjusted at the factory so that the generator produces the proper voltage and frequency. For normal usage, the speed setting should not be changed. If the generator is being run continuously on a very light load, it is often advisable to lower the operating speed slightly.

The engine will govern itself at full speed. Intentionally overriding the governor and operating the generator at low voltage may damage both the generator and any load connected to it. Running the engine at excessively high speeds results in high voltage, which may significantly shorten the life of light bulbs and appliances being used, as well as possibly damaging the engine.

**CAUTION: EQUIPMENT DAMAGE**  
**SPEED ADJUSTMENTS SHOULD ONLY BE MADE BY A QUALIFIED SERVICE TECH.**

Output voltage should be checked periodically to ensure continued proper operation of the generating plant and appliances.

## CONNECTING THE LOADS

The engine-generator covered in this manual was designed for portable use. Do NOT operate indoors. The unit should be stored in a warm, dry location. Move the unit outdoors to a flat, dry location for use.

### **WARNING: PERSONAL DANGER:**

*Operating any engine driven generator without proper air flow can result in personal injury or death. DO NOT operate this unit inside a home or garage, near vents or windows, or anywhere carbon monoxide gas could accumulate.*

Failure to properly limit and balance the load applied to the generator will cause the generator to produce low voltage and may damage the engine generator set. It may also cause severe damage to the loads connected to the generator at the time. Improper loading of the generator set constitutes abuse and will not be covered by warranty.

Your individual loads must be protected by individual circuit breakers mounted in some type of distribution panel. This location will also be where you will install your neutral to ground bond. You must wire four separate wires from the generator (2-hot, 1- neutral, and 1-ground) to the distribution panel.

## APPLYING THE LOADS

Allow the engine to warm up for two or three minutes before applying any load. This will allow the engine to reach normal operating temperature and oil to circulate throughout the engine. A short warm-up time will permit the engine to work more efficiently when the load is applied and will reduce the wear in the engine, extending its life. Receptacles have been provided to allow loads to be connected to the generator.

The loads should be added one at a time. If a large motor is being started: or multiple motors are being started, they should be started individually and the largest should be started first.

### **CAUTION: EQUIPMENT OVERLOAD**

*Keep the generator load within in the generator and receptacle nameplate rating. Overloading may cause damage to the generator and/or the loads.*

Most electric tools and appliances will have the voltage and amperage requirements on their individual nameplates. When in doubt, consult the manufacturer or a local electrician. The nameplate amperage rating for electric motors can be misleading. See "Starting Electric Motors" in the Unit Capabilities.

Proper utilization of the receptacles located on the control panel is necessary to prevent damage to either the receptacles or the generator. The generator is a limited source of electrical power, therefore, pay special attention to the receptacle and generator ratings. The nameplate rating can be obtained through a single receptacle as long as the receptacles amperage rating is not exceeded.



## GROUNDING

Proper grounding of your generator is application dependent. Carefully evaluate your planned use of your generator to understand which grounding you require. If you are not sure what to do, contact a competent professional to assist you. The NFPA 70 250:34-35 are good technical references.

## STANDARD PORTABLE GENERATOR

Your WINCO portable generator ships with a bonded neutral. You can safely use this generator without external grounding as long as all loads are powered through the receptacle panel.

## VEHICLE-MOUNTED GENERATOR

Your WINCO portable generator ships with a bonded neutral. When mounted to a vehicle to safely distribute power it is necessary that the generator frame is bonded to the vehicle frame. The generator should only supply equipment that is cord and plug connected through receptacles mounted on the generator or the vehicle.

## PERMANENTLY INSTALLED GENERATORS

This WINCO portable generator ships with a bonded neutral and overcurrent protection. NFPA 70 refers to this as a “separately derived system.” When connecting it to a building a transfer switch specifically designed for GFCI and bonded neutral generators is required.

## WIRING

Plug your tools such as drills, saws, blowers, sump pump, and other items to be powered directly into the generator receptacles. Before plugging in all the tools and cord sets, recheck the rating of the generator set. Be sure it can handle the intended load and is compatible with the voltage, phase, and current ratings. ‘Hard wiring’ this unit directly into a temporary construction site electrical system is **NOT A SIMPLE DO-IT-YOURSELF JOB**. For your safety, all wiring must be done by a qualified electrician and conform to the National Electric Code and comply with all state and local codes and regulations. Check with local authorities before proceeding.

### WARNING: PERSONAL DANGER

*A fully isolated, double pole double throw manual transfer switch must be installed any time a generator is being connected to an existing distribution system.*

These engine-generator sets are designed for portable light commercial use. Receptacles are provided on the control panel to permit 120 portable appliances and tools to be plugged directly into them.

## ENGINE CARE

### MAINTENANCE SCHEDULE

	Daily or Every 10 hrs	First Month or 5 hrs	Every 6 Months or 50 hrs	Every 100 hrs	Every 250* hrs
Check Oil	✓				
Change Oil		✓	✓		
Air Filter	✓				
Change Air Filter					✓
Spark Plug				✓	
Clean Spark Arrester					✓
Idle Speed				✓	
Clean Fuel Tank and Filter				✓	
Check Valve Clearance				✓	
Check Fuel Tube	Every 2 Years (replace if necessary)				
Clean Combustion Chamber					✓

\* If engine use is infrequent; every year

\*\* If engine use is infrequent; every 2 years

If you are using oil of a quality lower than the recommended one then you will have to replace it every 150 hours

If major engine service or repair is required, contact an authorized engine service center. The manufacturer of these engines has established an excellent world-wide engine service organization. Engine service is very likely available from a nearby authorized dealer or distributor.

## CHANGING THE OIL

### OIL RECOMMENDATIONS

Outdoor temperatures determine the proper oil viscosity for the engines. Use the chart to select the best viscosity for the outdoor temperature range expected.

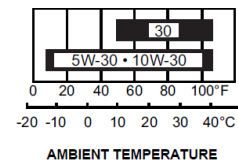

Change the oil after the first five hours of operation and every 50 hours thereafter under normal operating conditions. Change engine oil every 25 hours of operation if the engine is operated under heavy load, or in high ambient temperatures.

- A. Remove oil drain plug at base of the engine and drain the oil with the engine warm.

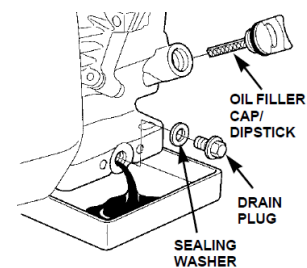

- B. Replace oil drain plug.
- C. Remove oil filler plug and refill with new oil. Refer to the table in the engine manual for the proper grade of oil based on your operating temperature.
- D. Replace filler plug.

## AIR FILTER

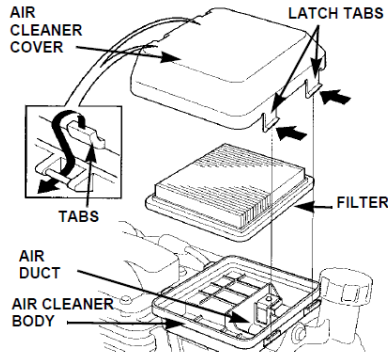

Remove and clean cartridge yearly or after every 25 hours, whichever occurs first. Service more often if necessary. Clean by tapping gently on flat surface. If very dirty, replace the cartridge using only original equipment parts available at any engine service center.

Do not use petroleum solvents, such as kerosene, to attempt to clean the cartridge. They may cause deterioration of the cartridge.

**DO NOT OIL CARTRIDGE.**  
**DO NOT USE PRESSURIZED AIR TO CLEAN OR DRY CARTRIDGE.**

## SPARK PLUG

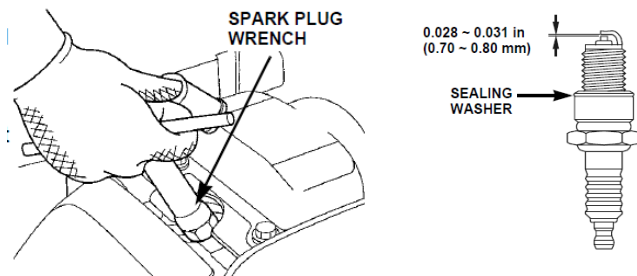

Clean and reset gap at .030" every 250 hours of operation. Do not blast clean spark plug. Clean by scraping or wire brushing and washing with a commercial solvent. Poor spark will occur if terminal does not fit firmly on spark plug. If this happens reform the terminal to fit firmly on spark plug tip.

## GENERATOR CARE

Proper care and maintenance of the generator is necessary to ensure a long trouble free life.

## EXERCISING THE GENERATOR

The generator should be operated every three to four weeks. It should be operated for a period of time sufficient to warm the unit up and to dry out any moisture that has accumulated in the windings. If left, this moisture can cause corrosion in the winding. Frequent operation of the engine-generator set will also ensure that the set is operating properly should it be needed in an emergency.

## GENERATOR MAINTENANCE

Any major generator service, including the installation or replacement of parts, should be performed only by a qualified electrical service technician. **USE ONLY FACTORY APPROVED REPAIR PARTS.**

- A. Bearing - The bearing used in these generators is a heavy duty, double sealed ball bearing. They require no maintenance or lubrication.
- B. Receptacles - Quality receptacles have been utilized. If a receptacle should become cracked or otherwise damaged, replace it. Using damaged or cracked receptacles can be both dangerous to the operator and destructive to the equipment.

## CLEANING

Remove dirt and debris with a cloth or brush. **DO NOT** use high pressure spray to clean either the engine or the generator. The high pressure spray could contaminate the fuel system and the generator components.

1. Keep the air inlet screen on both the engine and generator free of any dirt or debris to ensure proper cooling. At least yearly, remove the blower housing on the engine and clean the chaff and dirt out of the engine cooling fins and fly wheel. Clean more often if necessary. Failure to keep these areas clean may cause overheating and permanent damage to the unit.
2. Periodically clean muffler area to remove all grass, dirt, and combustible debris to prevent a fire.
3. On engine mufflers equipped with spark arresters, the spark arrester must be removed every 50 hours for cleaning and inspection. Replace if damaged.

# TROUBLESHOOTING

Problem	Possible Causes
Won't start	Low oil level Out of fuel ON/OFF switch in OFF position Fouled spark plug
Voltage too low	Engine speed is too low Generator overloaded Defective stator Defective rotor (field)
Circuit breaker trips	Defective load Defective receptacle
Voltage too high	Engine speed is too high
Generator overheating	Overloaded Insufficient ventilation
No output voltage	Short in load (disconnect) Broken or loose wire Defective receptacle No residual magnetism (in generator) Defective stator Defective rotor (field) Shorted capacitor GFCI receptacle tripped

## CONTROL PANEL WIRING DIAGRAM

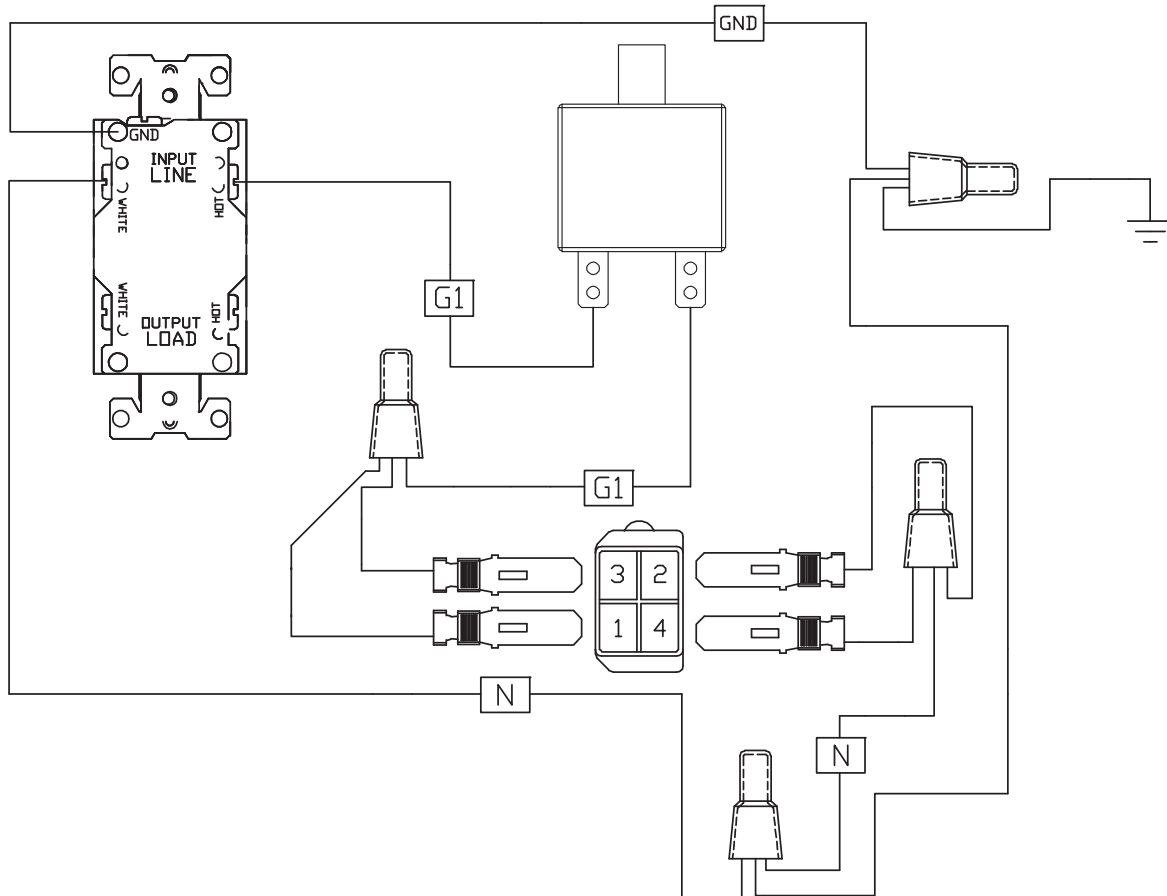



## 12 MONTH LIMITED WARRANTY

WINCO warrants to the original purchaser for 12 months, that goods manufactured or supplied by it will be free from defects in workmanship and material, provided such goods are installed, operated and maintained in accordance with WINCO written instructions and applicable codes.

WINCO's sole liability, and Purchaser's sole remedy for a failure under this warranty, shall be limited to the repair of the product. At WINCO's option, material found to be defective in material or workmanship under normal use and service will be repaired or replaced. For warranty service, return the product within the warranty period, to your nearest WINCO Authorized Service Center or to WINCO in Le Center Minnesota.

### Duration Consumer, Commercial and Rental

Parts & Labor: 12 Months

### EXCLUSIONS:

- Normal maintenance consumables or labor.
- This warranty does not cover travel time, mileage or labor for removal or re-installation of WINCO product from its application.
- Normal wear and tear.
- Costs of rental equipment.
- WINCO does not warrant engines. Engines are covered exclusively by the warranties of their respective manufacturers.
- WINCO does not warrant component parts that are warranted by their respective manufacturers.
- WINCO does not warrant modifications or alterations which were not made by WINCO.
- WINCO does not warrant products which have been subjected to misuse and/or negligence or have been involved in an accident.  
Proof of proper maintenance must be furnished upon request.

THERE ARE NO EXPRESS WARRANTIES OTHER THAN THOSE DESCRIBED HEREIN. THERE ARE NO OTHER WARRANTIES, EXPRESSED OR IMPLIED, OR OTHERWISE CREATED, INCLUDING BUT NOT LIMITED TO WARRANTIES OF MERCHANTABILITY, OR WARRANTIES OF FITNESS FOR A PARTICULAR PURPOSE.

WINCO is liable for the repair or replacement of the product only and is not liable for incidental or consequential damages as permitted by your state. This warranty gives you specific legal rights which may vary from state to state.