

## Features

### Honda GX160 Engine

You expect the best; you get the best. The GX160 lives up to the reputation of superior reliability and performance you expect from Honda.

### Low Oil Protection

In the event there is low oil level, the engine will shut down, and protect the engine from damage.

### Powder Coat Paint

For an incredibly durable finish.

### Sturdy Wrap-Around Welded Tubular Cradle

We use 14 gauge steel for dependable durability.

### Oversized Generator End

We oversized the generator end to improve small motor starting.

### 100% Load Tested

You won't find statistical sampling here. We load test every generator before it leaves our facility.

## DYNA PROFESSIONAL

**3,000 Starting Watts**  
**2,500 Running Watts**

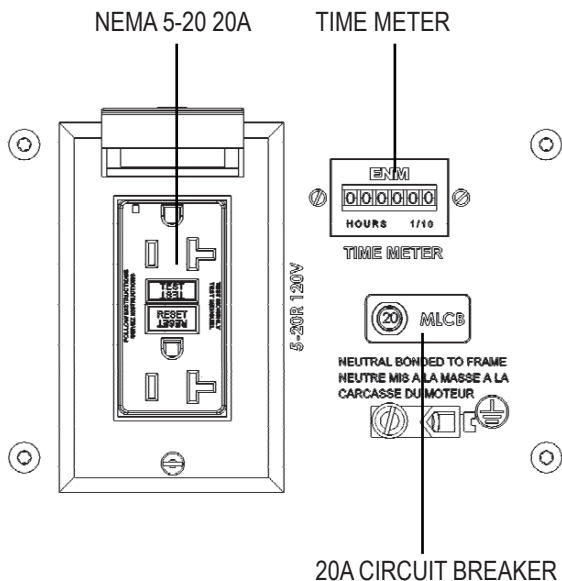
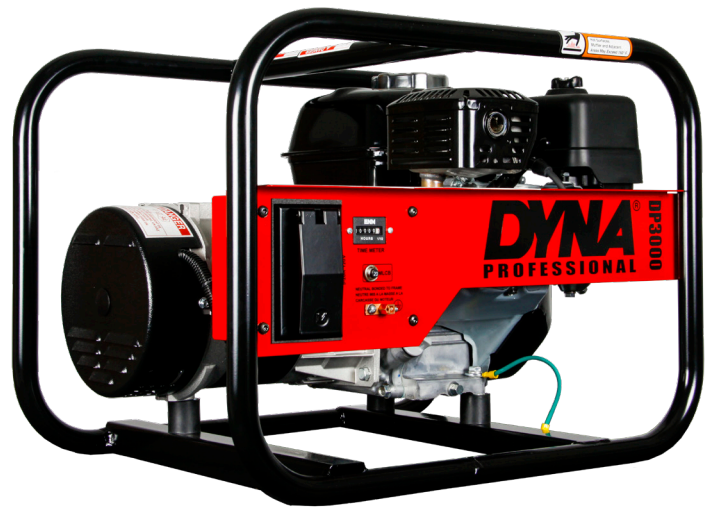

## Optional Accessories

### Plug-In Line Voltage Monitor

For when you want to verify the voltage output.

### Maintenance Kit

Keep the engine at its peak performance to ensure the generator will be ready when needed most.

## DP3000

|                                   |                      |
|-----------------------------------|----------------------|
| STARTING WATTS                    | 3,000                |
| RUNNING WATTS                     | 2,500                |
| RUNNING AMPS @120 VAC             | 20.8                 |
| VOLTAGE REGULATION                | CAPACITOR +/-5%      |
| FREQUENCY REGULATION              | +/-3%                |
| MAIN CIRCUIT BREAKER              | 20 AMP               |
| BONDED NEUTRAL                    | YES                  |
| 120 VOLT RECEPTACLES              | NEMA 5-20 20A (GFCI) |
| GENERATOR WARRANTY <sup>(1)</sup> | 3 YRS COMMERCIAL     |

NOTES: (1) For generator warranty information contact your local WINCO dealer.

## GENSET

|                                        |                  |
|----------------------------------------|------------------|
| MOTOR STARTING (CODE G) <sup>(1)</sup> | 1 HP             |
| SOUND DATA <sup>(2)</sup> FULL LOAD    | 74               |
| LIFTING EYE                            | NO               |
| PROTECTIVE ROLL FRAME                  | 14 GAUGE STEEL   |
| ASSEMBLED IN                           | USA              |
| EPA APPROVED                           | YES              |
| CARB APPROVED                          | YES              |
| CSA APPROVED                           | NO               |
| UNIT WARRANTY <sup>(3)</sup>           | 3 YRS COMMERCIAL |

NOTES: (1) Code G capacitor start motor. (2) All measurements are in db(a). Tested at 7 meters (23 ft.). (3) For more generator warranty information contact your local WINCO dealer.

## ENGINE

|                                |                  |
|--------------------------------|------------------|
| ENGINE BRAND                   | HONDA            |
| ENGINE MODEL                   | GX160 OHV        |
| ENGINE STARTER                 | RECOIL           |
| ENGINE SPEED                   | 3600 RPM         |
| ENGINE CYLINDERS               | SINGLE           |
| DISPLACEMENT/TYPE              | 160 CC / OHV     |
| LOW OIL PROTECTION             | STANDARD         |
| RECOMMENDED OIL                | 10W-30           |
| OIL CAPACITY <sup>(1)</sup>    | 0.6 QT           |
| FUEL TANK                      | 1 GAL            |
| FUEL GAUGE                     | NO               |
| FULL LOAD RUN TIME             | 2.2 HRS/GAL      |
| TIME METER                     | YES              |
| ENGINE WARRANTY <sup>(3)</sup> | 3 YRS COMMERCIAL |

NOTES: (1) The recommended oil is for normal applications. See operator's manual for the recommended oil for your needs. (2) Code G capacitor start motor. (3) Contact your local Honda service center for engine warranty assistance.

## DIMENSIONS

|            |                       |
|------------|-----------------------|
| DIMENSIONS | 22.5" x 16.5" x 16.5" |
| NET WEIGHT | 96 LBS                |

NOTES: Dimensions are L x W x H

## SHIPPING

|                     |                 |
|---------------------|-----------------|
| SHIPPING DIMENSIONS | 24" x 18" x 19" |
| SHIP WEIGHT         | 104 LBS         |
| FREIGHT CLASS       | 70              |

NOTES: Dimensions are L x W x H

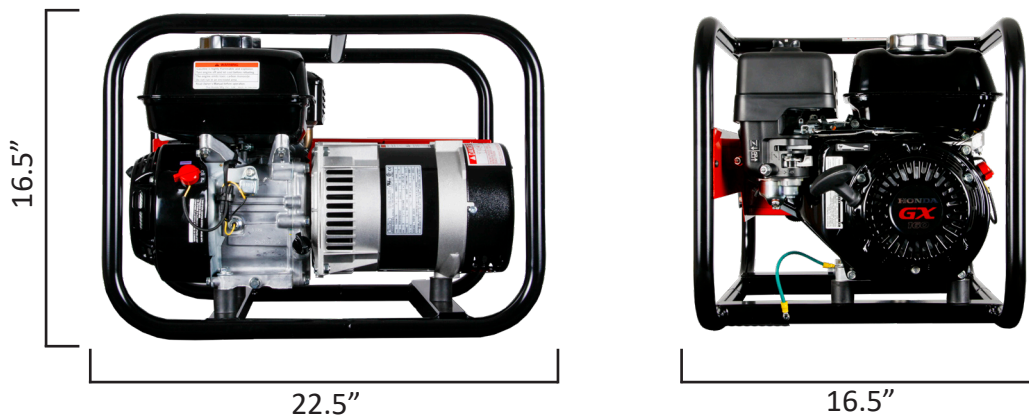

Specifications are subject to change without notice.