

WINCO[®] GENERATORS



An American Company

We produce our products in our 200,000 ft² facility located in Le Center, Minnesota, equipped with modern engineering, fabrication and assembly capabilities.



YOUR GEN



LED Display

Hours, RPMs, voltage, and frequency readings automatically cycle on the display.

Load Bars

Easily verify the load balance on each leg of the generator end.

Warnings

The LED will flash if any parameter gets outside of normal range. A warning will also be displayed when it is time for an oil change.

Receptacle Panel

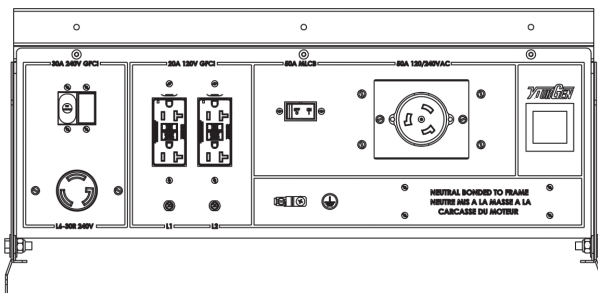

DP14000VE-03/A

11,760 WATTS

Rugged Steel Design.



B & S Commercial Vanguard Engine.

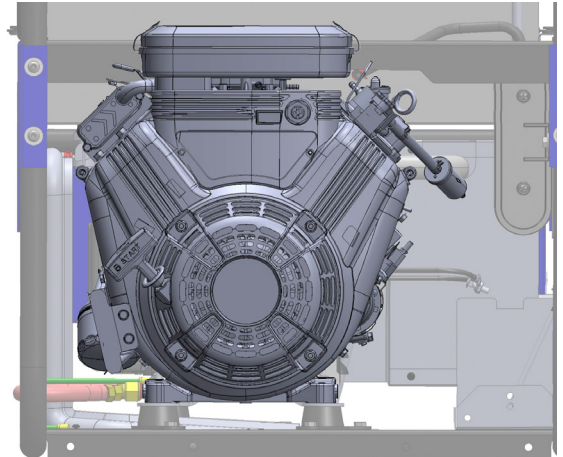

Brushless Industrial Genend.

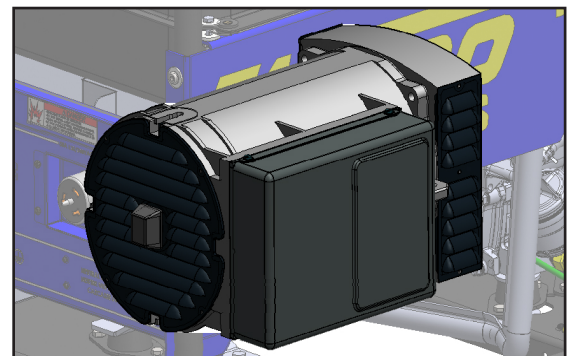

SPECIFICATIONS

ENGINE

ENGINE BRAND	BRIGGS & STRATTON
ENGINE MODEL	VANGUARD
ENGINE STARTER	ELECTRIC
ENGINE SPEED	3600 RPM
ENGINE CYLINDERS	V-TWIN
DISPLACEMENT/TYPE	627 CC / OHV
FREQUENCY REGULATION ⁽¹⁾	+/- 3%
LOW OIL PROTECTION	STANDARD
RECOMMENDED OIL ⁽²⁾	5W-30
OIL CAPACITY	1.5 QT
FUEL TANK	15 GAL
FUEL GAUGE	YES
FULL LOAD RUN TIME ⁽³⁾	8.8 HOURS
FUEL CONSUMPTION	GAL/HR
100%	1.70
75%	1.40
50%	1.20
25%	0.76
BATTERY SIZE ⁽⁴⁾	BCI GROUP U1 300CCA

NOTES: (1) Steady state frequency regulation. (2) The recommended oil is for normal applications. See operator's manual for the recommended oil for your needs. (3) Run time is estimated. (4) Battery not included.

SHIPPING

SHIPPING DIMENSIONS (L x W x H)	50" x 27" x 35"
SHIP WEIGHT	423 LBS
FREIGHT CLASS	70

OPTIONAL ACCESSORIES

FOUR-WHEEL DOLLY KIT	WITH FLAT-FREE TIRES
COVER	45" x 32" x 30"
BATTERY	BCI GROUP U1 300 CCA
MAINTENANCE KIT	16200-007

ELECTRICAL

STARTING WATTS	14,000
RUNNING WATTS	11,760
RUNNING AMPS @ 120 VAC	98
RUNNING AMPS @ 240 VAC	49
VOLTAGE REGULATION	CAPACITOR +/- 5%
MAIN CIRCUIT BREAKER	60 AMP, 240V VAC
BONDED NEUTRAL	YES
120 VOLT RECEPTACLES	(2) NEMA 5-20 20A DUPLEX (GFCI)
120/240 VOLT RECEPTACLES	(1) C6365 50A T-L
240 VOLT RECEPTACLE	(1) NEMA L6-30 30A (GFCI)
YOURGEN METER	STANDARD

GENSET

MOTOR STARTING (CODE G)	4 HP
DBA @ 7 METERS	80
TOTAL HARMONIC DISTORTION	< 5%
LIFTING EYE ⁽¹⁾	STANDARD
4-WHEEL DOLLY KIT	OPTIONAL
INSULATION	CLASS H
PROTECTIVE ROLL FRAME	1.25" DIA. 14 GA. STEEL
ASSEMBLED IN	USA
EPA APPROVED	YES
CARB APPROVED	NO
TÜV CSA CERTIFICATION	YES
UNIT WARRANTY ⁽²⁾	3 YEARS COMMERCIAL

NOTES: (1) Lifting eye shipped loose. (2) For more generator warranty, see operator's manual.

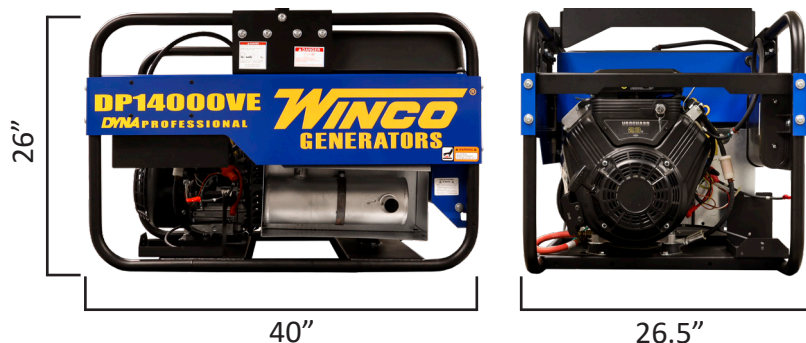

Specifications are subject to change without notice.

