

# WINGCO<sup>®</sup> GENERATORS



## An American Company

We produce our products in our 200,000ft<sup>2</sup> facility located in Le Center, Minnesota, equipped with modern engineering, fabrication and assembly capabilities.



## Full Load Tested

Every generator is 100% load tested



## DSE 7310 Controller

Provides immediate performance information



## Coolant Heater

120V in-line Hotstart coolant heater with thermostat



## Battery Charger

5 Amp, smart marine charger standard



## TÜV Certified

The design, construction, and performance of our stationary generators conform to UL2200 & CSA standards



# DR45F4

45,000 WATTS

Rugged Design  
Galvanized steel enclosure with powder coat paint



## Industrial FPT Engine

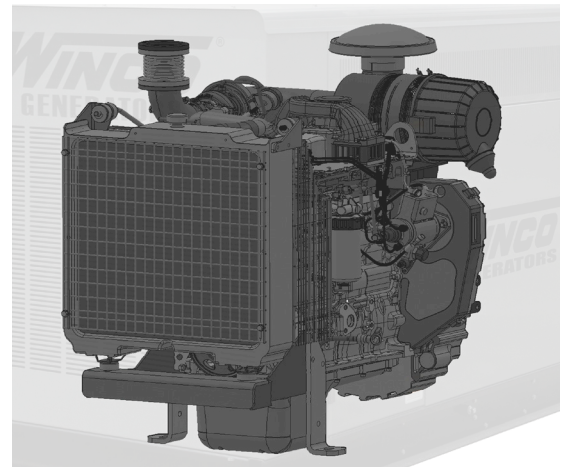

## Cummins Industrial Genend.

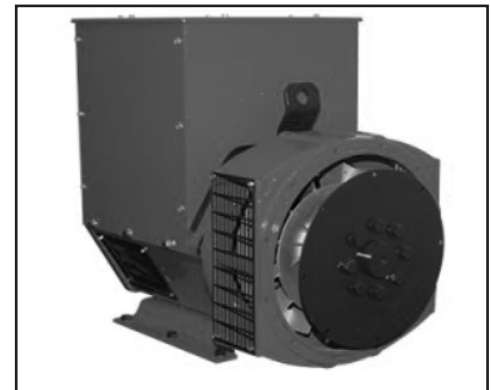

# SPECIFICATIONS

## ELECTRICAL

VOLTS	POWER FACTOR	STANDBY			PRIME			CIRCUIT BREAKER
		WATTS	KVA	AMPS	WATTS	KVA	AMPS	
120/240 1-PH	1.0	45,000	45	187	40,500	40.5	168	200
120/208 3-PH	0.8	45,000	56	156	40,500	50	140	150
120/240 3-PH	0.8	45,000	56	135	40,500	50	121	150
277/480 3-PH	0.8	45,000	56	68	40,500	50	60	70
346/600 3-PH	0.8	45,000	56	54	40,500	50	48	70

## ENGINE

ENGINE BRAND	FPT
ENGINE MODEL	N45 SM1
TIER	III
ENGINE STARTER	12V ELECTRIC
ENGINE SPEED	1800 RPM
ENGINE CYLINDERS	4
ENGINE HP	76
FREQUENCY	60 HZ
ALTERNATOR	90 AMPS 14V
FLYWHEEL	11.5"
ROTATION	CCW
ASPIRATION	TURBOCHARGED
COOLANT	1.9 GAL
BORE/STROKE	104 mm x 132 mm
DISPLACEMENT	4.5 L
RECOMMENDED OIL <sup>(2)</sup>	5W-40 SAE
OIL CAPACITY	9 QT
INJECTION PUMP	STANADYNE TYPE
GOVERNOR	MECHANICAL
COMPRESSION RATIO	17.5:1
FAN TYPE	PUSHER
INTAKE AIR CONSUMPTION	189 CFM
RADIATOR COOLING AIR	4873 CFM
EXHAUST FLOW	195 CFM
EXHAUST OUTLET SIZE	3"
STARTING TEMP W/BLOCK HEATER	-20° F

NOTES: (1) Steady state frequency regulation. (2) The recommended oil is for normal applications. See operator's manual for the recommended oil for your needs. (3) Battery not included.

## DBA @ 7 METERS

FULL LOAD	74
-----------	----

## DR45

MOTOR STARTING (CODE G)	20 HP
TOTAL HARMONIC DISTORTION	< 5%
FLOATING NEUTRAL	YES
FORK LIFT POCKETS	NO
ASSEMBLED IN	USA
EPA APPROVED	TIER III (STANDBY)
CARB APPROVED	TIER III (STANDBY)
TÜV CERTIFICATION	UL2200 CSA
UNIT WARRANTY <sup>(1)</sup>	
STANDBY	2 YEAR/2000 HRS

NOTES: (1) For more generator warranty, see operator's manual.

## GENERATOR END

WINDING	
SINGLE PHASE	4 LEAD
THREE PHASE	12 LEAD
WINDING NUMBER	
SINGLE PHASE	06
THREE PHASE	311
VOLTAGE REGULATION	AVR +/- 1%
AVR TYPE	AS440
TEMPERATURE RISE	125/40° C
BRUSHLESS	YES
SPEED	1800 RPM
ROTOR	2/3 PITCH
WINDINGS	100% COPPER
STATOR WINDING	
06	SINGLE LAYER CONCENTRIC
311	DOUBLE LAYER CONCENTRIC
COUPLING	DIRECT/FLEXIBLE DISC
BEARINGS	SINGLE (MAINTENANCE FREE)
EFFICIENCY PEAK	
SINGLE PHASE 1.0 PF	84.0
THREE PHASE 0.8 PF	89.4
INSULATION	CLASS H
INGRESS PROTECTION	IP23

# SPECIFICATIONS

## BLOCK HEATER

VOLTS	120
WATTS	1,800
AMPS	15
THERMOSTAT	
ON	100° F
OFF	120° F

## DERATES

ABOVE SEA LEVEL	
3281- 9843 FT	2% EVERY 1641 FT
>9843 FT	4% EVERY 1641 FT
AMBIENT TEMPERATURE	
>104° F	2% PER 10° F

## FUEL

TYPE	ASTM D975 NO-2D DIESEL
FUEL CONSUMPTION	GAL/HR
100%	3.90
75%	3.00
50%	2.10
25%	1.17
OPTIONAL FUEL TANK	L x W x H
180 GAL UL142	108" x 42" x 17"
320 GAL UL142	108" x 42" x 29"

## DSE 7310 CONTROLLER

### ENGINE DISPLAY/PROTECTION

ENGINE RPM	YES
LOW OIL PRESSURE	YES
HIGH COOLANT TEMP	YES
LOW COOLANT	YES
OVER/UNDER SPEED	YES
OVER CRANK	YES
CAN ECU SHUTDOWN	YES
ENGINE MAINTENANCE CODES	YES

### GENSET DISPLAY/PROTECTION

VOLTAGE (L-N & L-L)	YES
OVER/UNDER VOLTAGE	YES
FREQUENCY	YES
OVER/UNDER FREQUENCY	YES
AMP DISPLAY/SHUTDOWN	YES
PHASE IMBALANCE	FIELD ENABLED
KW, KVA, KVARH DISPLAY	YES
KWH, KVAH, KVARH DISPLAY	YES
GENERATOR PHASE SEQUENCE	OPTIONAL

## BATTERY

DC SYSTEM	12V
BATTERY RACK/CABLE	INCLUDED
BATTERY CHARGER	5 AMP
REQUIRED BATTERY <sup>(1)</sup>	GROUP 24 650 CCA

NOTES: (1) Battery not included.

## SHIPPING

SHIPPING DIMENSIONS (L x W x H)	115.5" x 48" x 65"
SHIP WEIGHT	3,425 LBS
FREIGHT CLASS	70

NOTES: Shipping dimensions are for an enclosed unit.

## OPTIONAL ACCESSORIES

BATTERY
BATTERY HEATER
RECEPTACLE PANEL
MIMIC PANEL
REMOTE MONITORING
NFPA 110 LEVEL 1 UPGRADE
MAINTENANCE KIT
WINCO SYNTHETIC OIL

### ADDITIONAL DISPLAYS/PROTECTIONS

EXTERNAL E-STOP	FIELD INSTALLED
BATTERY VOLTAGE	YES
BATTERY OVER/UNDER VOLTAGE	YES

### COMMUNICATIONS

USB CONNECTABLE	YES
RS232/RS485	YES
REMOTE DISPLAY PANEL	OPTIONAL
DSE WEB NET	OPTIONAL

### ADDITIONAL FEATURES

AUDIBLE ALARM	YES
ENGINE EXERCISER	DISABLED
MAINTENANCE INTERVAL TIMER	DISABLED
LOAD SHEDDING/DUMMY	DISABLED
CONFIGURABLE INPUTS	4 (EXPANDABLE)
CONFIGURABLE OUTPUTS	4 (EXPANDABLE)
EVENT LOG	250

Specifications are subject to change without notice.

